

HEPA SHIELD

The HEPA Shield system represents one of the most powerful HEPA air filtration systems on the market today and is used in applications around the world.

MODEL	CFM
600HS	600
1200HS	1200
2000HS	2000

The HEPA Shield comes in three different models:

All models come in two versions; the “L” version or vertical configuration and the “S” version or horizontal configuration. Either of these configurations can be used in conjunction with any heating/cooling system or as stand-alone units in applications where central filtration is not necessary.

Each model is available with two different controller options for the PLUS line of systems. Couple the ECM motor with our HVAC controller and the system will run in conjunction with most HVAC systems. Should you need more flexibility in volume control or want the system to run independently; the VCU digital controller allows for volume control from 1-100% in 1% increments.

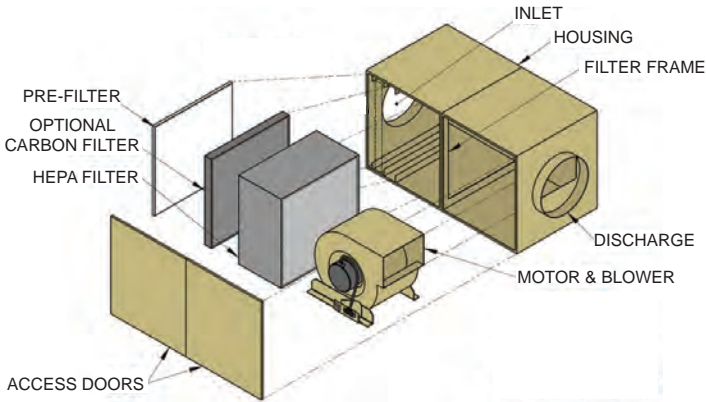

“S” Version

TRUE HEPA FILTRATION

Certified HEPA removes 99.99% of all particles 0.3 microns and larger

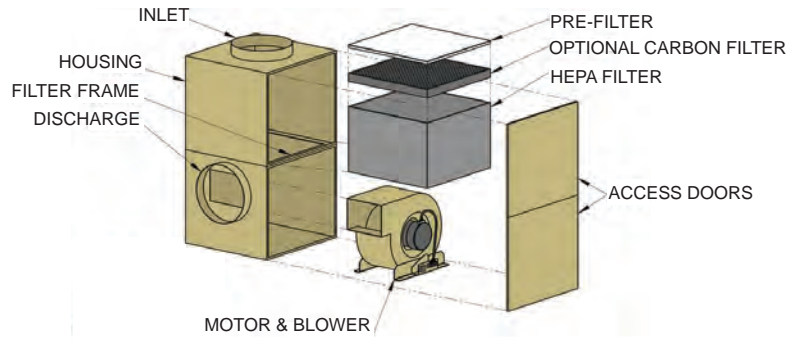

“L” Version

THREE STAGE FILTRATION

1. Polyester Prefilter MERV 8
2. Carbon Filter
3. True 99.99% HEPA Filter



3747 N. Booth St. Milwaukee, WI 53212 USA

T: (414) 962-5323, (877) 532-5323

F: (414) 962-7003

cservice@esca-tech.com www.esca-tech.com

DESIGN SPECIFICATIONS AND OPTIONS

	MODEL 600HS	MODEL 1200HS	MODEL 2000HS
Dimensions "L" Unit	16 1/4" D x 16 1/4" W x 34" H	25" D x 25" W x 42" H	25" D x 25" W x 42" H
Dimensions "S" Unit	16 1/4" D x 16 1/4" H x 34" L	25" D x 25" H x 48" L	25" D x 25" H x 48" L
Duct Connections	12" Dia. Inlet, 10" Dia. Outlet	14" Dia. Inlet and Outlet	14" Dia. Inlet and Outlet
Weight "L" Unit	97 lbs (with all filters)	180 lbs (with all filters)	180 lbs (with all filters)
Weight "S" Unit	97 lbs (with all filters)	200 lbs (with all filters)	200 lbs (with all filters)
Max CFM Rating	600 CFM	1200 CFM	2000 CFM
Electrical	120 volt, 15 Amp Circuit	120 volt, 15 Amp Circuit	120 volt, 15 Amp Circuit
Motor	1/3 HP ECM Variable Speed 120/240 volt 50/60Hz	3/4 HP ECM Variable Speed 120/240 volt 50/60Hz	1 HP ECM Variable Speed 120/240 volt 50/60Hz
Filters	Polyester Ring Panel Prefilter 5 lb Carbon Media 99.99% HEPA at 0.3 Microns	Polyester Ring Panel (Dual-Layer) 15 lb Carbon Media 99.99% Certified Filter	Polyester Ring Panel (Dual-Layer) 15 lb Carbon Media 99.99% Certified Filter
Controls	Lighted on/off Rocker Switch 8 Amp Breaker	Lighted on/off Rocker Switch 15 Amp Breaker	Lighted on/off Rocker Switch 15 Amp Breaker
Optional Digital Controllers	HVAC Controller or Digital Speed Controller	HVAC Controller or Digital Speed Controller	HVAC Controller or Digital Speed Controller

OPTIONAL 1200OA UNIT 1. "L" Unit add 2 carbons in-lieu of HEPA (45lbs) 2. "S" Unit add 4 carbons in-lieu of HEPA (75lbs)

